

RADIO CONSTRUCTOR

OCT
1948

for Every Radio Enthusiast

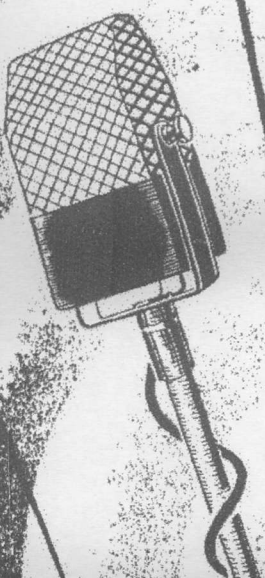

★

Contents

THE TYPE 24 RF UNIT. Modifications on this popular surplus unit.
Power Transformers Query Corner
THE SIXTY THREE VALVER. A Low-cost receiver for the amateur bands.
INEXPENSIVE TELEVISION Part 3 of the series.
Radio Matching Calculations Radio Simplified Trade Review Trade Notes Book Review From the Mailbag, etc.

★

You **MUST** have a copy of
The **SHORT WAVE
LISTENERS ANNUAL**

● (1948 EDITION) ●

Remember what the experts said about the 1947 Edition ?

X This popular publication is brimful of interest and contains what must surely be one of the most comprehensive lists of SW stations. In every sense a most useful book and one which every short wave enthusiast should have on his bookshelf.

—*Incorporated Radio Society of Great Britain.*

X A booklet of genuine usefulness to all walks of people engaged in short wave listening, is informative, and covers every aspect of the short wave field.—*Ultra Electric Limited.*

X Most interesting publication that has come to my attention this year. The "Annual" is the most comprehensive of its kind I have yet seen and it should prove of material assistance to those

who secure a copy. It should be "required reading" for the short wave fan.

—*Kenneth Boord, DX Editor, writing in "Radio News," (U.S.A.).*

X To my mind this is the most comprehensive publication of its kind that I have seen. I will go so far as to say that it is invaluable to anyone, no matter how experienced he may be in SW listening. This publication is a "must."

—*Bex Gillett, DX Editor of "Radio Call" (Australia).*

X The fame of your "Annual" is already spreading far and wide.—*E. Bernold, Vice-President, Pan-American Broadcasting Co. (N.Y.).*

NOW READ WHAT WE OFFER
IN THE NEW EDITION

112 PAGES crammed with DX data

- Call Signs, Country Lists, Radio Zones, Call Areas.
- Society QSL Bureaux of the World, Broadcast Station Addresses.
- Tabulated Schedules, International Codes.
- Identification of SW Stations, Station Slogans.
- International Short Wave League Section.
- Propagation of Short Wave Radio Waves.
- Amateur Codes, Postal Data, Time Conversion, When to Listen, Distance Table, Time Check Transmissions, State and Zone Record Tables.
- Broadcast Station List (according to operating frequency).
- DX Maps.

Now available from your local bookseller at **3/6**

or 3/9 post free from:—

Amalgamated Short Wave Press Limited, 57 Maida Vale, Paddington, London, W.9



Radio Constructor

Vol. 2, No. 3

Annual Subscription 16/-

October, 1948

Editors:

ARTHUR C. GEE, G2UK

W. NORMAN STEVENS, G3AKA

Technical Editor:

LIONEL E. HOWES, G3AYA

Advertisement & Business Manager:

C. W. C. OVERLAND, G2ATV

Editorial

YOU'VE had it. The "summer" we mean. Which all goes to show that before we know where we are winter—or more appropriately The Season—will be upon us. This is the time of year when constructors dust off the bench and clean up and sharpen tools in preparation for the winter's orgy of construction; when the DX gang get down to more intensive work and get even more excited over new catches; when club secretaries report a greater attendance at meetings. All this exemplifies The Season. When you read these lines it will be on!

As far as the constructor goes, he will carry on in his usual way. He will have various, often, let it be said, original, ideas on how to do certain jobs, how to overcome certain difficulties and how to avoid various snags. He will take all this for granted. He will seldom realise that other constructors may not know these things. We can classify the items collectively as Dodges.

Some dodges are universally known. Others are lesser known. How would you make an insulated washer if no insulating material was available? One dodge is to use thin card (a postcard is suitable), shaped into two washers. Then soak them in varnish or "coil dope." Talking about coil dope, do you know that you can make an effective substitute by dissolving perspex in switch cleaner fluid? How can a small capacitor be made? One way is to use a strip of, say, 16 swg wire and cover with sleeving. Then wind, with thinner wire, over the sleeving a short coil. Solder the turns so that they are "shorted" to remove any inductive

effect. You then have your capacitor. How would you tackle an awkward shaped hole, say for an escutcheon? You could use an "Abrafile" in a hacksaw frame and do in two minutes what normally would take as much as half an hour. By the way, the "Abrafile" costs only 9d., plus 4½d. for hacksaw adaptors, from local toolshops.

These are typical dodges. You may know them already, or you may have learnt something new! Taking into account the enormous number of constructors there must obviously be hundreds of dodges in general use. By dodges we mean the practical ones and not some of those fanciful ideas one sometimes sees published.

DODGES

What are your pet dodges? We would like to hear from you and should they be reasonably practical we would be pleased to publish them. Don't hide your light under a bushel—let others know about your artifice! As we said before, you may be able to help others by telling them about your pet wheezes. After all, the ham spirit says that we must help our fellow enthusiasts, so how about dropping a line to us so that we may disclose to an awe inspired readership the little dodges of which you hold the secret? We do not, however, want to know how to make a soldering iron from a gas pipe, a yard of string, a cocoa tin and a pot of glue! This type of thing is not a dodge—though they should be dodged!

W.N.S.

NOTICES

THE EDITORS invite original contributions on construction of radio subjects. All material used will be paid for. Articles should be clearly written, preferably typewritten, and photographs should be clear and sharp. Diagrams need not be large or perfectly drawn, as our draughtsman will redraw in most cases, but relevant information should be included. All MSS must be accompanied by a stamped addressed envelope for reply or

return. Each item must bear the sender's name and address.

COMPONENT REVIEW. Manufacturers, publishers, etc., are invited to submit samples or information of new products for review in this section.

ALL CORRESPONDENCE should be addressed to *Radio Constructor*, 57, Maida Vale, Paddington, London, W.9. Telephone: CUN. 6579.

AUTHENTIC AND UP-TO-THE-MINUTE INFORMATION ON VHF, BROADCAST BAND AND AMATEUR ACTIVITIES IS GIVEN IN OUR MONTHLY PUBLICATION "SHORT WAVE NEWS."

The Type 24 RF Unit

Modifying the Unit for 14-21-28 Mcs. amateur bands.

By A. Hitchcock - ISWL/G280

NO doubt many readers have purchased on the surplus market one of the excellent ex-R.A.F. RF Units—Types 24, 25, 26 and 27, at prices varying from approximately 10/- to 25/-. These units, used in the "Gee" Airborne Equipment, are of first-class construction, as is all Air Ministry equipment. For those interested, the frequency coverage of the individual unit is as follows:—

RF unit Type 24	20-30 Mcs.
" " " 25	40-50 "
" " " 26	50-65 "
" " " 27	65-85 "

This information, together with circuits of all units and associated equipment is contained in the official Air Ministry publication A.P.2557A, Vol. 1.

The main receiver in use at present at my address is a Canadian 103A 7-valve superhet. As this only covered 1.7 Mcs.—7.5 Mcs. in two

bands, the need was felt for something for the higher frequencies, namely the 10, 15 and 20 metre amateur bands. Another receiver would be very useful, but like many other SWL's, I didn't feel absolutely financially stable, and then again, a multi-band receiver is liable to fall off in efficiency as it approaches, say, 30 Mcs. Nothing really complicated was desired, and I only wanted one tuning control if possible. It was with these points in mind that I purchased an RF unit Type 24. Note the type number, this is important. No coil modifications are required in this model. The circuit of the Type 24 unit is given in Fig. 1. This is as used in its original form in the "Gee" equipment. Frequencies are "spot" tuned by a five-position ceramic switch, this bringing into use different capacitors and resistors on each of the switch positions. In the theoretical circuit in my particular copy of the A.P. 2557A the values of capacitors C43 and C44 are not given, but as this is not required

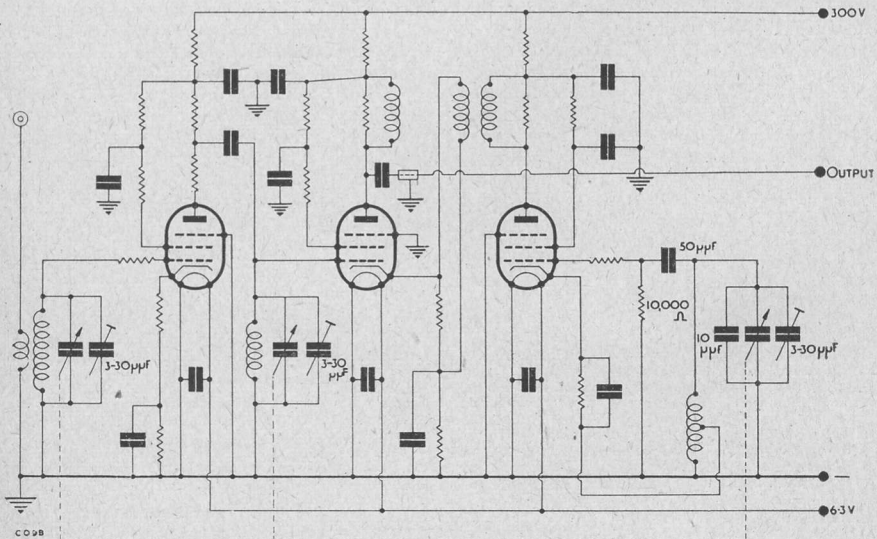

Fig. 2. The modified circuit.

in our model we need not worry about them. Also, details of coils and transformer T1 are not included. No further comment need be made on this circuit as all capacitors and resistors associated with the switch are removed, as shown by the modified circuit of Fig. 2. The sub-chassis on the unit can be forgotten, and is of course correctly wired anyway. Nothing need be touched anywhere underneath the deck. The only juggling with mine was to obtain the connections for the six-pin Jones plug at the back. The correct connections for this are included in one of the diagrams.

As mentioned previously, only one control was required, and in the design which follows this has been achieved.

To commence with, remove the ceramic switch, and all capacitors and resistors. Also the trimmers, which are of the usual Philips concentric type. Notice that the 2 μ F pipe across the oscillator screen is also taken out. In the oscillator section will be found a ceramic bush which needs to be moved to the other hole directly below it. This helps to shorten wiring.

Replace three of the concentric trimmers back in the positions shown in the photo, taking care that the "stator" tag is turned to obtain the shortest possible wiring. Do not attempt to wire anything up yet. The next problem was tuning capacitors. A most diligent search was made for some really small ones, but nothing was forthcoming—most of them looking too clumsy. Eventually I fell on my feet when a friend gave me three air-spaced trimmers from a dismantled VHF test set. These, after a little work, proved to be ideal in physical size and capacitance. When obtained, as there was no spindle on the back end, it was thought that it would be an impossibility to gang them up. However, this was not to be. For those in search of the capacitors, the following information may help. They are made by "Wingrove & Rogers (Polar) Ltd.," and have three rotor and

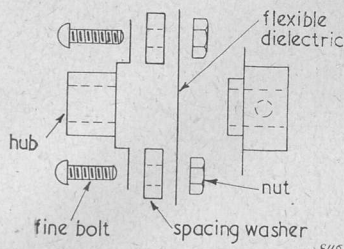

Fig. 4. Method of lengthening coupler.

four stator vanes. The insulation is ceramic. To modify them proceed as follows: Grip the spindle ($\frac{1}{4}$ " long) in a lathe chuck, or anything else suitable, and drill the main rotor spindle $\frac{1}{16}$ " dia. by $\frac{7}{32}$ " deep. (I did mine in a vice, and guessed the centre, but only because I did not have access to a lathe). Now carefully tap down 10BA. These taps are very frail, so emphasis is laid on the word "carefully." Only treat two of the variables in the above manner, the other one being in the oscillator stage at the rear. Proceed next with the extension spindles. These are made by turning to the sizes shown from $\frac{1}{4}$ " dia. brass bar. Before cutting off to length, it is advisable to thread the pin 10BA to correspond with the tapped hole in the variable capacitor. This being done, it now remains to solder the extension spindle in. To do this, turn the variable to minimum capacitance, and remove the split washer at the front end. The rotor spindle will now slide out completely. Screw home the newly made spindle, hold in a gas jet and apply solder on the joint accordingly. Before replacing, slacken the tension on the three-armed spring. Grease the spindle, and replace as before. The capacitors are now ready for mounting. The correct position can be seen in the photograph. Modified flexible couplers were used between the capacitors, the modification consisting of drilling out the original rivets, and putting washers of insulating material between to "lengthen" the coupler. This, of course, is only a minor detail, and may not be necessary, depending on what flexible couplers the constructor uses. In any case, they are essential. Firstly, for smooth operation, and secondly, they take strain off the dial mechanism. A word here concerning the dial. In my particular case a Muirhead 40-1 reduction drive, taken from an RAF receiver Type 1082, was used. This is complete with dial lamp on top. Unfortunately, the lamp fouled the aerial socket, so a new panel had to be made with the aerial socket offset to clear the obstruction. All other measurements on the original panel were adhered to. As in the previous paragraph, this again may not be necessary.

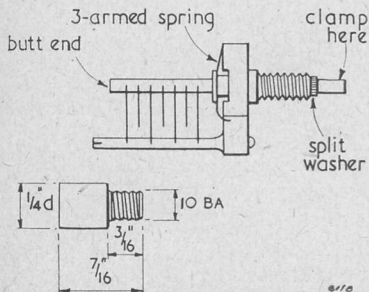
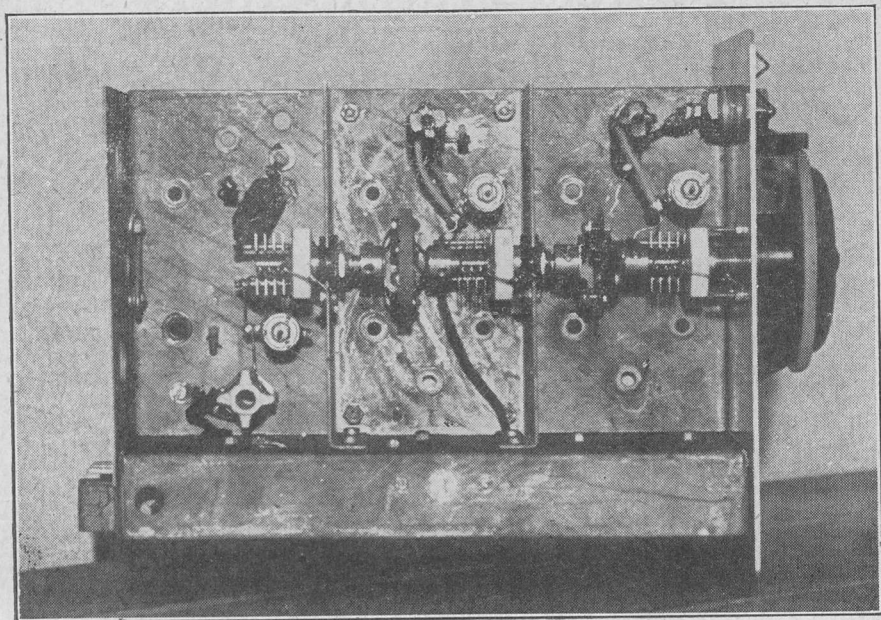

Fig. 3. Showing details of the new extension spindle, etc. The butt-end of the variable is drilled $\frac{1}{16}$ " dia and tapped 10 BA. Depth of hole is $\frac{7}{32}$ ".

To return now to the wiring. As can be seen in the photo, the RF stage variable is set back from the panel on spacing washers, due to



Top view of the modified unit, showing details of the coupling.

the dial, but as just stated, this may not be needed.

Wire everything up straight and direct, using, say, 20 swg tinned copper wire. As only the grid wiring of each stage is to be put back, it is not necessary here to describe the point-to-point wiring. Just refer to the theoretical diagram, you can't go wrong. Here should be mentioned the oscillator stage wiring. Just visible below the variable can be seen a disc-type fixed capacitor. This is wired across the trimmer for this stage, and is 10 μF capacitance, taken from the "heap" of those originally removed. Also, do not forget the grid leak and capacitor. Respectively, they are 10 K Ω and 50 μF .

Each of the variable capacitors is earthed to a solder tag bolted on each panel.

Well, that's the mechanical side of it finished. It may sound a deuce of a lot of hard work, but it isn't really. And now for tuning. The 30 Mcs. band was "found" on the oscillator trimmer, and then peaked up the other two.

Every constructor has his own ideas on lining up. A signal generator is very suitable, or what have you. I made the mistake of trimming the job whilst out of its metal case, so please do not fall for this mistake, or otherwise 10 metres will practically vanish when the unit is put back in its box! Earth the unit, or you may get severe hand capacity. The IF of this unit is 7.5 Mcs. despite the fact that some advertisers quote 7 Mcs.

The signal-to-noise ratio on my particular model was fair, but apart from testing it out for an hour or so, not much listening has been done, so that DX results cannot be specified. The writer is one of those who, as soon as a job is completed, has to start a fresh one because the interest has completely vanished.

In conclusion, I may add that the total financial outlay for my unit as it now stands was 18s. 6d. including the dial and Jones' plug; so what more could anyone want.

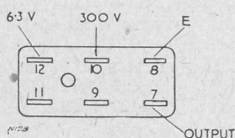

Fig. 5. Sketch of "Jones Plug," numbered as on the unit.

Power Transformers

By *Gene Zap*

BEFORE getting down to the practical side of power transformers it would be as well, for the sake of the beginner, to briefly consider the principles on which they operate. When a current passes through a coil of wire a field of force is set up in the space surrounding it and as this current ceases the field collapses. Thus if the supply of current to the first (or primary) coil is alternately allowed to flow and be interrupted, we have a state of this field rising and falling with the supply. This is precisely what happens whether the current is supplied by AC, when it rises to maximum and falls through zero and back again to maximum with each cycle, or whether it is supplied in the form of pulsating DC from a vibrator where the current circuit is repeatedly made and broken.

A second coil, adjacently placed to the primary coil, will pick up the current in the field surrounding it. This occurs whether or not an iron core is used and a common example of this is found in our tuning and IF circuits. In power transformers an iron core is used and it should be noted that this core is not solid but built up in the form of separate laminations to minimize losses due to eddy currents.

Losses.

It is usual for each lamination to be separated from its neighbour by a thin film of paper glued to it, by enamel or shellac, and sometimes the iron oxide surface (which forms during the manufacture only) serves as the insulator. Losses are reduced by using thin laminations, although they don't look so impressive as stout rigid sheets often seen in vibrator transformers. The transformer core material may be of soft iron, or, in the more modern types, of silicon steel, which has a higher power rating.

The voltage picked up in the second (or secondary) coil is proportional to the number of turns it contains in its ratio to the primary. Where the secondary has twice the number of turns as the primary (to which the current is supplied) the voltage appearing across the secondary is twice as great. The current, of course, is halved—you don't get something for nothing.

If the secondary has four times as many turns as the primary the voltage is quadrupled and the current quartered. Conversely a smaller voltage at a heavier current can be drawn from a step down ratio.

When several secondaries draw current from the same primary this rule still holds good for

each of the windings, but, of course, the primary must be capable of handling the total current drawn.

Efficiency.

The full transference of power from the primary to the secondaries is theoretical and is based on the assumption that the efficiency of the transformer is 100% and that the resistance of the windings is nil, but up to this stage we have only concerned ourselves with theory. In practice the efficiency is less than 100%. This does not mean we get less voltage (pressure); it means that we get less current. If we have an equal number of turns in both the primary and secondary and supply 200 volts to the former, we get 200 volts appearing in the secondary, and if the current drawn from it is 90 mA the primary must be capable of handling a current of 100 mA. The 10% loss of efficiency is wasted in the form of heat.

Eddy current losses to which we have already referred, are due to the movement of lines of force across the core, causing heat and the reduction of overall efficiency. The magnetic flux, too, lags behind the magnetising force producing it. This lag is known as hysteresis, causing heat due to molecular friction as the magnetising flux changes.

There is, of course, a point where a further increase in the magnetising flux does not increase the flux density, but merely excessive heat. This condition is known as saturation.

The question of the resistance of the windings is relatively unimportant in small transformers except where large windings of fine gauge wire are used, or when a very heavy current is drawn. Where a very high standard of precision is needed, the slight loss due to resistance can be corrected by a few extra turns.

Practical Considerations.

It will be seen, when the foregoing principles are applied, that home construction of power transformers is no formidable task for those who have the patience and aptitude for this kind of work. It is chiefly a matter of giving due care to the calculation of the number of turns for each winding, the size of the core, the wire gauges to be used and care with thorough insulation.

In either purchasing or making, it is well to make sure that the transformer is of sufficient power to cover not only immediate needs with a safety margin, but with an eye to probable

future needs even if only in the same receiver. Every real constructor will at some time want to add either a BFO, a magic eye, a pre-selector or VHF converter, warning lamps, push-pull output, to say nothing of the possible additions for future FM transmissions. To this end the problem of "regulation" is important.

Regulation briefly means the ability of a transformer to maintain a reasonably constant voltage output with varying loads, and this virtue is dependent upon good design. The winding area should be filled—this can be assured in home-constructed jobs by reference to wire tables when the most suitable gauges can be found, and a large gap between the windings and the outer limbs avoided.

In determining the gauge to be used for the primary winding due allowance must be made for efficiency losses, which even in a good design will be at least 10%. Incidentally the temperature rise after many hours working should be scarcely detectable by feeling with the hand.

An electrostatic screen is wound over the primary, although this is not essential, and is often omitted for the sake of cheapness. It will, however, prevent interference in the form of RF currents appearing in the primary from being introduced into the secondary windings. This screen may consist of a layer of foil, or be a single layer of insulated wire with one end brought out to earth and the other carefully insulated and anchored inside. If a foil electrostatic screen is used, care must be taken to ensure a gap is left of the ends fully insulated where they overlap. A lead is taken from the foil for earthing.

Turns Per Volt.

The chief factor deciding the number of turns per volt is the size of the cross sectional area of the core. Other factors are the flux density of the core in lines per square cm. and the frequency (periodicity) of the supply.

Having decided upon the total load for a transformer, that is the total power from ALL the secondary windings PLUS the allowance for loss of efficiency, we can settle on the size of the core required which will also determine the number of turns per volt, from the following table:

Cross Section in square inches.	Turns per Volt.	Watts.
1.5	5.3	50
2.25	3.5	100
2.5	3.2	150
3.0	2.7	200

Reference to a copper wire table* will enable current carrying capacity to be found and also the number of turns per inch.

Add, say, 40% to allow for paper insulation between the layers and for thicker arithmetical between the windings, and a little arithmetic

calculation will show whether the "window" area will accommodate the required windings. It must be borne in mind that a single short-circuited turn will cause a heavy current flow in that particular turn which will first scorch and then burn the insulation of adjacent turns, resulting finally in a burn-out of the whole winding.

It is customary to use iron of a flux density about 30% lower for transformers to be used in conjunction with vibratory converters. This in turn means an increase of the same percentage in the turns-per-volt figure. The flux density by the way, of normal iron lamination is usually somewhere between 6,000 and 8,000 lines.

As the vast majority of transformers made up by home constructors are rewinds of burnt-out jobs, the turns-per-volt ratio can well be noted upon stripping down. It is perhaps too obvious for me to need to add that with careful side by side winding there is no need to count the individual number of turns. Simply count the first layer and verify the space occupied with the known number of turns per inch—then only a note of the number of layers need be kept.

To conclude with a practical example. A transformer for an average superhet receiver.

	Watts.
Valve heaters, 6.3 v. @ .3 amp. (3)	
6.3 v. @ .45 amp. (1)	8.5
Rectifier, 5 v. @ 2 amps.	10
HT, 350 v. @ 70 mA.	24.5
Allowances for losses	5
	48

Suitable core-size, 1.5 square inches.

Primary at 250 v., 1,325 turns. Tapped at 1,060 turns for 200 v., and at 1,220 turns for 230 v. Wound with 26 s.w.g.

Secondaries: Heater, 34 turns of 18 s.w.g. Rectifier, 27 turns of 16 s.w.g. HT, 3,710 turns, centre tapped, of 32 s.w.g.

From a copper wire data table it is a simple calculation to ascertain how much space these windings will occupy. Allowance of up to 40% additional space should be made for the interleaving paper, the inter-winding insulation and for the electrostatic screen. If the window area is still not comfortably filled use next thicker gauges of wire—it is always as well to be on the safe side.

It is advisable to allow an additional turn on each of the heater and rectifier windings to compensate for resistance of windings and possible lengthy leads. The interleaving paper can well be stripped from an old Mansbridge type capacitor, which is both highly satisfactory from both the insulation and the space saving viewpoints. The use of adhesives is not advised where it is likely to get on the enamel of the wiring. There is always a danger of chemical damage to the enamel and adhesive insulating tape (or empire cloth), or even a smear of pitch melted on, is infinitely better.

*See *Radio Constructor*, July, 1948, page 316.

Query Corner

A "Radio Constructor" service for readers



Local Station Interference.

"I have constructed a superhet tuning unit for use with a high quality amplifier. Quality is good but for an interfering Morse signal, which varies only slightly in intensity when the tuning capacitor is rotated. The interference is stronger when the tuning is set to the upper end of the medium wave band. Can you suggest its cause and cure?"

E. Wakefield, Clacton.

Whistles and interference of the type in question are still all too prevalent in the home constructed superhet, and we cannot stress too highly the need for careful layout and screening of components. There is no doubt that, before commencing construction, a few hours spent in planning the mechanical side of the receiver will be well repaid with improved performance. Now the type of interference experienced by our correspondent is due to the reception of a signal which is either on, or very near, the intermediate frequency. Such an interfering signal may be the result of poor screening or the reception of two signals separated by the intermediate frequency and thus producing a resultant or beat frequency. There are many different combinations of frequencies which may result in the type of interference in question, but in general they are of such a small amplitude that they may be neglected. In almost all cases, however, the trouble is characterised by the fact that the amplitude of the interfering signal increases as the receiver is tuned towards the upper end of the medium wave band, or in other words, when it is tuned towards the normal intermediate frequency of 465 kcs. (650 metres approx.).



COSG

Fig. 1. The Acceptor Circuit. The coil may be taken from an IF transformer.

So far this explanation may have seemed a little complex, but, fortunately, whatever the cause of the trouble, the cure is the same, the fitting of an IF acceptor circuit across the RF side of the receiver. A suitable acceptor may be made from a discarded IF transformer, the coil and capacitor being connected in series as shown in Fig. 1. The acceptor may be connected either across the input to the frequency changer or between aerial and earth, a little experimental work in this connection will soon indicate the best position. The iron core of the coil or the present capacitor which constitutes the acceptor circuit should be adjusted so that the circuit is tuned to the intermediate frequency. In the absence of a signal generator this may be achieved by trimming for optimum results.

We will leave the subject of interference in superhets by saying that in the near future it is hoped to publish an article dealing with every cause of the trouble.

Electrolytics Again.

"Whilst taking some voltage and current measurements on my receiver I noticed that the electrolytic capacitors passed a current of between 0 and 2 mA. Does this mean that the life of those passing 2 mA. is drawing to a close?"

F. Harlow, Norwich.

Electrolytic capacitors may be divided into two types, the wet type and the dry type. The principle of operation is the same for both, but the construction is somewhat different. The dry electrolytic consists of two strips of aluminium foil separated by paper or fabric which is impregnated with a conducting fluid. The wet type, on the other hand, is enclosed in a metal can which forms the negative plate, the positive plate being positioned centrally within the can. The space between the plates is filled by the conducting fluid, which consists mainly of a solution of boric acid and ammonia. Before the capacitors are assembled an oxide film is deposited on the positive plate by electrolysis. It is this film which forms the dielectric between the positive plate and the fluid, which in turn is in contact with the negative plate. The wet type of capacitor normally has some form of "breather" in the top of the can to allow any vaporised fluid to escape without causing damage. The dry type, however, is sealed to avoid the loss of the fluid with which the material used to separate the plates is impregnated. Should the case become punctured the material will soon become dry and the capacity of the electrolytic will be considerably reduced.

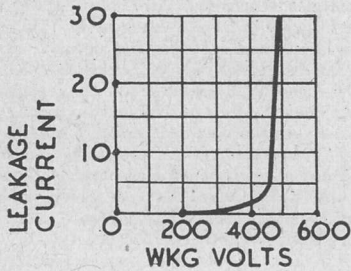

Fig. 2. Leakage characteristics of a typical 16 μ F, 400 V, wet electrolytic capacitor.

The maximum working voltage of electrolytic capacitors is stated by the manufacturers to be a little lower than the voltage used by them to deposit the dielectric film on the positive plate. This provides a small margin of safety before the maximum peak voltage is exceeded and the leakage current becomes excessively large. Fig. 2 shows a typical curve of leakage current plotted against applied voltage for a 16 μ F 400V. wkg. wet type electrolytic. It will be seen that once the maximum voltage is exceeded the leakage current becomes unduly high; if this is allowed to occur the dielectric film will be punctured and the capacitor ruined. In order to obtain the maximum length of life from electrolytics care must be taken never to reverse their polarity, never to exceed their working voltage, to mount in a cool part of the receiver, and finally, to operate wet electrolytics only in a vertical position.

“Query Corner” Rules

- (1) A nominal fee of 1/- will be made for each query.
- (2) Queries on any subject relating to technical radio or electrical matters will be accepted, though it will not be possible to provide complete circuit diagrams for the more complex receivers, transmitters and the like.
- (3) Complete circuits of equipment may be submitted to us before construction is commenced. This will ensure that component values are correct and that the circuit is theoretically sound.
- (4) All queries will receive critical scrutiny and replies will be as comprehensive as possible.
- (5) Correspondence to be addressed to “Query Corner,” Radio Constructor, 57, Maida Vale, Paddington, London, W.9.
- (6) A selection of those queries with the more general interest will be reproduced in these pages each month.

Energised Speakers.

“I have converted my AC receiver to operate from DC mains, but am at a loss to know how to energise the speaker field, as when connected in the HT+ lead it reduces my voltage to about 100 V. Can you suggest an alternative method of connecting the field energising coil?”

J. Orr, Worthing.

Generally speaking mains energised loud speakers are only used in universal receivers when the valves are intended for use on an HT voltage of around 100 V. This is because the energising field of the speaker magnet has appreciable resistance, and when connected in the HT line may quite easily result in a voltage drop of 100 V. It is, however, possible to shunt the field winding across the HT line in a DC receiver without any reduction in voltage. Fig. 3 shows the method of connection, the capacitor across the winding being for the purpose of smoothing any ripple which may be present on the mains supply. The value of the resistance R may be found by using Ohms Law, and should be of such a value that the current in the speaker field is sufficient to fully energise it. A typical value of “R” for a 2,000 ohms 8 watt field, and a 200 volt line, is 1,200 ohms.

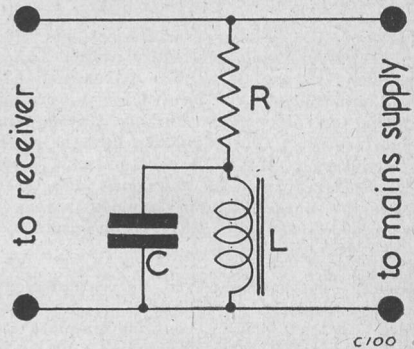

Fig. 3. Shunt connection for mains energised speaker field.

“C” is the smoothing capacitor and can be 2 μ F or more.

BOOK RECEIVED.

“Short-Wave Reception and Transmission” is the title of a book published by W. Foulsham & Co., Ltd., the author of which will be well-known to readers of “Radio Constructor”—W. Oliver, G3XT.

This book, illustrated with line drawings, has 110 pages and contains Chapters on receiving gear, operating short-wave receivers, broadcasting stations, building a simple transmitter, learning morse, simple fault finding and so forth.

Priced at 2/6 the book will appeal to those about to commence short-wave activities and will serve as a useful introduction to the hobby.

TRADE NOTES

Ohms Law Reference Chart : We have received a sample of this chart from the manufacturers Messrs. Rummery & Co., Austin House Chambers, North Street, Guildford. The chart is actually a cardboard disc of five inches diameter. It is split into four sections, Volts, Amps, Resistance and Watts; each of these sections being subdivided into three further sections. The four main divisions are each printed in a different colour.

This chart was not designed to give a worked calculation, but to give a handy quick reference to Ohm's Law formulae for the amateur where calculations needing application of Ohm's Law are required. Each section of the circle shows one unknown quantity and three Ohm's Law formulae for finding the unknown. Simplified equations are also shown for easy calculation.

For those who do not yet fully understand the working of Ohm's Law and for those who have an unhappy knack of forgetting formulae this chart would prove to be a most handy accessory to have on hand. Taking into account the modest price of 1/- (post paid) the chart is a useful item and well worth the "bob."

Philco. The Philco Corporation of Philadelphia has recently formed a wholly British Subsidiary known as Philco (Overseas) Ltd. This company has been formed for the purpose of selling in all export markets British-made Philco products. The managing director of the new company is Mr. R. W. Cotton, who, it will be remembered, was the managing director of British Rola until 1945 and a previous managing director of Philco Radio & Television Corporation of Great Britain Limited.

Denco. We have received the second Denco Technical Bulletin. DTB2 has for its subject Denco Coil Turrets and it contains complete data and recommended circuits, including a design for an All Wave receiver using the turret type CT6. Some of the features in the bulletin are General Consideration of Turrets, Construction and Technical Descriptions, Recommended Application of Turrets, and details for constructing a receiver using the CT6 turret.

The section on the receiver is most complete and includes, apart from excellent drawing showing wiring of the turret, components layouts and method of fixing a cord drive, full details from the constructional and technical aspects. Sections on checking and operating, alignment procedure and many useful tips are included. A kit of parts for the receiver is obtainable from Messrs. Denco.

The bulletin is well printed on art paper and has 32 pages plus a stiff cover. Copies may be obtained at 3/- from Denco (Clacton) Ltd., 355-9 Old Road, Clacton-on-Sea, Essex.

Catalogues Received. Two new catalogues of radio components have been received this month. The first is from Messrs. Radiocraft Limited (11, Church Road, Upper Norwood, London, S.E.19). Besides a useful array of transformers, chassis, chokes, and miscellaneous items, there are details of complete transmitters, modulators, VFO's, converters, receivers and so forth. Details are also given of Radiocraft's Constructional and Maintenance Services which will be of interest to many radio enthusiasts. Staff call-signs are G3PS, G400, G2FPP and G3CMS. The list TR3 may be obtained on request to the address given above.

H. Whitaker (G3SJ) of 10 Yorkshire Street, Burnley, provides the second catalogue. Listed are many items of general interest such as crystals, including many suitable for harmonic output for the VHF bands, power supplies, amplifiers, wavemeters and a host of other gear. G3SJ assures a ready welcome at the above address to any visiting ham.

AC/DC Short Wave Superhet.

Its those gremlins again! We apologise to the author, R. J. Appleby, and to any readers inconvenienced thereby for the errors in the article (pp. 358-362, September issue). The series resistor R32 should read 47 Ω and not 47 k Ω . The heater sequence should read 8, 7, 6, 3, 2, 1, 4, 5 to chassis. (The draughtsman responsible has been shot at dawn!).

Omissions were the values of R11 (330 Ω), C13 (15 μF), C5/C23 (both 0.01 μF). Sorry, chaps.

Inexpensive Television.

Readers will be sorry to hear that one of the co-authors of this series, G3AYA, has unfortunately contracted pleurosy and is therefore confined to his bed in the Central Middlesex Hospital. We are pleased to say that Lionel is now greatly improved but it may be some weeks before he is fully fit again.

The consequence of this sudden illness is that 2ATV has been left to carry on the articles alone—hence the omission of the tube network, etc., for the 5CPI version. We hope to be able to insert the missing details as soon as Lionel is sufficiently fit and in the meantime, rather than disappoint readers, we are carrying on with the details of the television of 2ATV's which uses the VCR97 tube.

Incidentally, those interested in television are referred to the announcement of our new magazine which appears on page 403.

The R1116A

Reader A. W. Mann (62, Costa Street, Middlesborough) wishes to loan a manual giving details of the above receiver. Will any member who has this manual please contact Mr. Mann who would be extremely gratified and willing to cover any costs involved.

The G3XT Three-Valver

*A simple low-cost receiver
for the amateur bands*

By W. OLIVER
G3XT

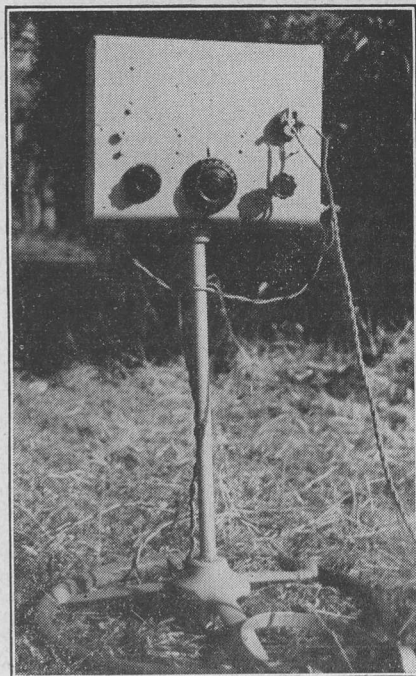

A GLANCE through my log shows that the best reports on my signals come from operators with first-class communication receivers; the second best from those with simple home-built sets; and the least satisfactory from those with complicated but inefficient receiving gear falling midway between these two extremes.

If, therefore, you cannot afford a first-class communications receiver, the next best thing seems to be a simple set of the O-v-1 or O-v-2 type. I have used the latter for reception in nearly all my QRP work at G3XT, and have secured, up to the time of writing, successful contacts with nearly 1,000 different stations, mostly on the overcrowded 7 Mcs band. As the majority of these stations have been contacted more than once, the total number of QSO's is well over 2,000. All but a few of these have yielded 100 per cent. "solid" copy on the three-valve receiver at G3XT.

This seems to prove that such a simple receiver, if properly built and handled, can hold its own even under present-day conditions of interference on the amateur bands.

The circuit (Fig. 1) is straightforward; the decoupling is generous, and doubtless helps a lot in securing the silent "background" which enables me to read nearly every signal I can hear at all on the set. Signal-to-noise ratio is, in my opinion, more important than mere selectivity. A good operator can read weak signals through heavy interference from other stations on adjacent frequencies, but no one

can read a signal that is engulfed in heavy background noise.

Naturally the selectivity of an O-v-2 cannot compare with that of a first-class superhet. But in actual practice I find I can get 100 per cent. "solid" copy from almost any station that other operators are able to read on their own more elaborate receivers. The very light aerial coupling (I use a single turn coupling coil even on frequencies as low as 7 and 3.5 Mcs) is a great help in making the set more selective than this type of circuit is popularly supposed to be.

The light aerial coupling also plays an essential part in ensuring stability, constancy of calibration, freedom from hand-capacity, smooth reaction and suchlike attributes that are usually associated with the use of an RF buffer stage between the aerial and the detector circuit. It is found that if the aerial coupling is slackened off enough, one gets all these advantages without the use of an RF stage; and the only important drawback seems to lie in the loss of signal-strength. For DX work an RF stage would doubtless be an advantage, but up to 1,000 miles or so I find that signals average 559 to 599 in RST on my own receiver, using headphones and the circuit shown in Fig. 1.

Another factor which helps stability, freedom from hand-capacity, etc., is the metal case and chassis, details of which can be seen in the photos. The metal case used in the original model cost next to nothing, as it was the lid of a Government surplus ex-Air Ministry test

set. If you cannot get one from this source, a few hours planning and work will enable you to make a similar case out of sheet metal, or get one made to your specification by a firm that specializes in this sort of work (such as Messrs. Philpot's, of Loughborough).

A metal shelf or chassis mounted half-way up the inside of the case carries the valves, transformer and decoupling network. The three variable capacitors—bandset, bandspread and reaction respectively—are mounted on the metal case, in the lower half, and the remaining odds and ends are either mounted on the metal case or suspended in the wiring.

All wiring connections are made with short, direct wires of a gauge heavy enough to give rigidity, and all of the connections are soldered carefully to ensure good contact.

A four-pin valveholder can be used as the coil-holder, and as for the coils themselves, one can use either standard four-pin plug-in coils, or home-made ones of a similar type. In the latter case it scarcely matters which terminals on the coil-holder you use for the respective connections, provided of course that you arrange the connections to the coil pins in a corresponding fashion. But if ready-made coils are to be used instead, you must of course adhere to the standardized connections prescribed by the makers of the coils.

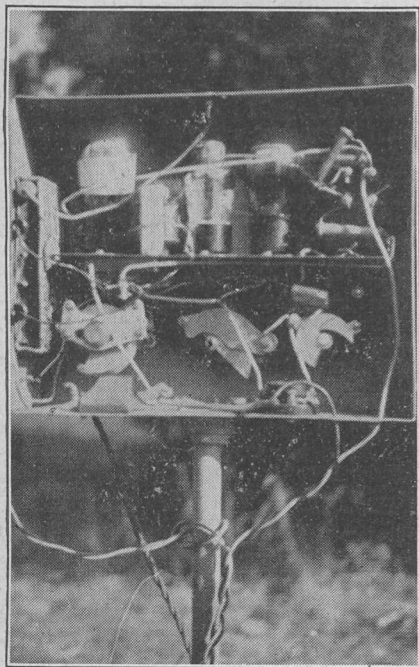

Rear view of the receiver showing layout.

As the components in this set are laid out in several different planes, it is difficult to show the details clearly in a conventional layout and wiring diagram, so a point-to-point wiring guide will help to simplify the wiring and also the checking of connections before switching on the finished set for testing:—

Aerial to coupling coil, coupling coil to chassis (optional).

Top of grid coil to stator vanes of C1 and C2 and to one side of C5. Other side of C5 to grid of V1 and top of R1.

Anode of V1 to one end of reaction coil and one end of RFC.

Other end of reaction coil to one side of C4; other side of C4 to stator vanes of C3.

One filament terminal of each valveholder to LT positive.

Remaining side of RFC to R3 and C6; other side of R3 to R4 and C7; other side of R4, one side of R5 and one headphone terminal to HT positive.

Remaining side of C6 to one end of R2 and grid of V2; other end of R2 to GB negative No. 1.

Remaining side of R5 to one end of transformer primary winding; other end of transformer primary to anode of V2.

One end of transformer secondary to grid of V3 (control grid).

Screening grid (if any) of V3 to HT positive, and to C9 (if included). Anode of V3 to negative headphone terminal.

Junction of R5 and transformer primary to C8.

Remaining filament terminal of each valveholder to chassis, or if an on-off switch is included, to one side of switch, other side of switch being earthed to chassis.

The remaining end of transformer secondary to GB negative 2.

Chassis or case to GB positive.

The following remaining connections are earthed to the chassis and metal case:

Rotor vanes of C1, C2 and C3; remaining end of R1; LT negative and HT negative; remaining side of C7, C8 and C9 (if included).

The foregoing list, together with the circuit diagram and other illustrations, should make wiring-up quite an easy job. The aerial coupling coil, as already mentioned, consists of a single turn of thick, rigid copper wire with one end on the stand-off insulator carrying the aerial terminal and the other end either carried on another insulator or connected direct to chassis. (Both ways can be tried to see which gives best results. On my own set I find an earth connection unnecessary, and the aerial coupling coil is not connected to chassis—it is simply a spiral termination to the aerial lead! But it works very well!)

A six-pin type of coil can be used if preferred, but the much larger aerial coupling coil and tighter coupling in this kind of inductor is, in my opinion, likely to nullify some of the most attractive features of the set, such as stability,

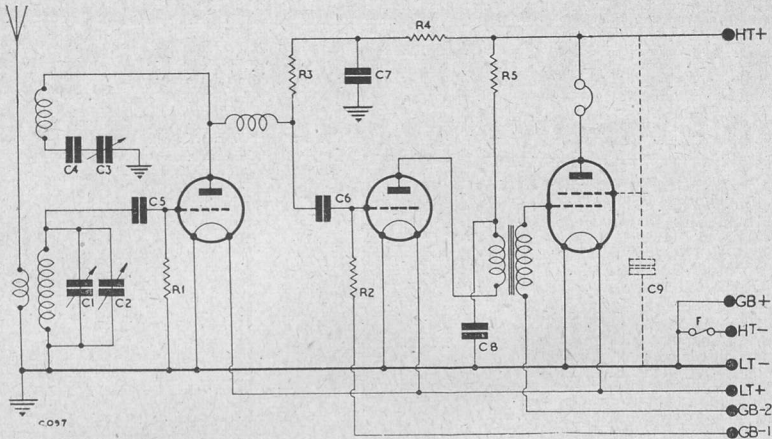

The dotted lines shown in output stage apply only if a pentode output valve is used.

THE G3XT THREE-VALVER

List of Components.

- C1 100 μF (60-250 μF).
- C2 40 μF (20-50 μF).
- C3 200 μF (100-500 μF).
- C4 0.01 μF (0.001-1 μF).
- C5 300 μF (100-500 μF).
- C6 0.1 μF (0.05-0.2 μF).
- C7 2 μF (1-4 μF).
- C8 2 μF (1-4 μF).
- C9 2 μF (1-4 μF) (if used).
- R1 3 M Ω (1.5 M Ω).
- R2 1 M Ω (0.5-1.5 M Ω).
- R3 50,000 Ω (30,000-60,000 Ω).
- R4 20,000 Ω (10,000-30,000 Ω).
- R5 20,000 Ω (10,000-30,000 Ω).

Note.—Capacity and resistance values are not very critical, and for those who wish to

experiment with parts already in hand, maximum and minimum limits are suggested in brackets.)

Set of 4-pin short-wave coils (commercial or home-made); 2 valveholders, 4-pin type; 1 valveholder, 5-pin type; 1 coil holder (or 4-pin valveholder); 1 R.F.C., short-wave type; 1 LF intervalve transformer, ratio 1-3 or 1-5; 1 stand-off insulator; terminals, screws, wire, etc.; chassis, case and stand to specification (see text and diagrams); battery leads, plugs, etc.; 1 on-off switch (optional—LT leads can be disconnected at accumulator if preferred); phone jack (optional); 1 detector valve (triode), 1 LF valve (triode) and 1 output valve (triode, tetrode or pentode). 2-volt LT, 120-volt HT, and 9-volt GB. 1 fuse and fuseholder.

smoothness of reaction, freedom from hand-capacity, constancy of calibration, etc., and also impair selectivity, although as a compensating factor the larger coil will doubtless give much stronger signals. This is a doubtful advantage as the majority of signals on the original model come in at S5 to S9 plus on headphones under normal conditions, so there is little point in stepping up the signal input from the aerial.

A refinement which might be added with advantage is a volume control across the secondary of the LF transformer. This would probably help still further in reducing background noise.

It will be seen from the two photographs that the set is mounted in a most unconventional and novel way! It is carried on a swivel arrangement at the head of an inverted steering column and steering wheel obtained from a car-breaker's

dump. The wheel makes a firm, stable base to stand on the floor, and the column, which is cut off with a hacksaw to a suitable height, brings the set to a convenient level for operation from one's easy chair. The simple swivel mounting enables the whole set to be swung round into a position that makes for easy tuning and accurate dial-reading.

I find this set very useful for break-in working, in conjunction with my low-power transmitters; and it is useful to add a simple make-and-break switch in series with the aerial, so that the latter can be disconnected for monitoring the signal from one's own transmitter. With the aerial thus disconnected, a CW signal from a transmitter with a power of 5 watts or less can be heard quite naturally with the reaction well advanced, and does not "block" the set as it does if the aerial is on.

(continued on page 404)

CLYDESDALE

FOR BARGAINS IN EX-SERVICE

BRAND NEW, in maker's cartons
Ex. R.A.F.

R.F. Unit 26 for 65-50 mcs.
5-6 metres.

R.F. Unit 27 for 85-65 mcs.
3.5-5 metres.

in popular use as convertors.

Each unit complete with 3 valves
VR136's (EF54) VR137 (EC52),
S.M. Tuning, etc., etc., contained
in neat metal case $9\frac{1}{2} \times 7\frac{1}{2} \times 4\frac{1}{2}$ ins.
Voltages required H.T. 250V.
L.T. 6.3V.

CLYDESDALE'S PRICE ONLY **35/-** each. POST PAID

6 way Jones type Flex Socket in metal cable entry cover, for
R.F. 27, 26, 25, 24 etc.

CLYDESDALE'S PRICE ONLY **3/6** each. POST PAID
6 for 17/6d. 12 for 30/-.

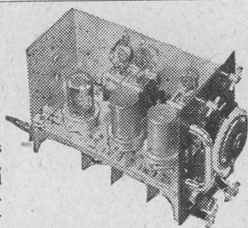

Ex. R.A.F.

Aircraft XMTR- T. 1154 Transmitter

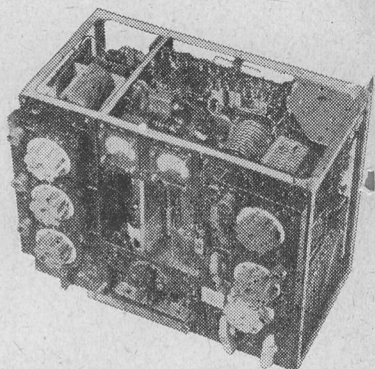

For "Fone." C.W. and M.C.W. complete
with Valves, Circuit and plugs, etc., in
metal case $14 \times 16\frac{1}{2} \times 8\frac{1}{2}$ ins. less power pack.

CLYDESDALE'S PRICE

ONLY **£10/10/0** each.
CARRIAGE AND PACKING PAID.
Full details on request.

BRAND NEW, in maker's cartons.

MUIRHEAD SLOW MOTION DRIVE

Ratio 48-1 dia., 3 in., fits standard spindle, drilled for
escutcheon, milled edge on main drive, metal locking tongue.

CLYDESDALE'S PRICE ONLY **7/6** each. POST PAID

2 for 13/6d.

BRAND NEW, in maker's cartons.

MUIRHEAD SLOW MOTION DRIVE

With dial 180-0, and indice dia. knob 3in. overall 4in. as used
in R1224, Wave meters, etc., fits standard spindle.

CLYDESDALE'S PRICE ONLY **12/6** each. POST PAID

BRAND NEW, in maker's cartons.

VERNIER SLOW MOTION DRIVE

With dial 180-0, and indice, with provision for illumination
dia. 3in., overall as used in R.F. 26, 27, etc., fits standard spindle.

CLYDESDALE'S PRICE ONLY **9/6** each. POST PAID

BRAND NEW—Ex. R.A.F.

High Impedance Headphones. (S. G. Brown) Total imp.
4,000 ohms. Ask for H.I.P.4KE.

CLYDESDALE'S PRICE ONLY **7/6** per pair. POST PAID

Two pairs for 12/6d.

BRAND NEW

MIC. & HEADPHONE ASSEMBLY in makers box



Carbon Power Mic
(Tannoy) in diecast hand
piece with press switch.
Moving Coil H'phones
(40 ohm. Coil sealed and
moisture proof with rubber
earpieces all wired to a
5 point moulded rubber
plug.

Ask for D14.
CLYDESDALE'S PRICE

ONLY **15/6** per set.
POST PAID

Power Units for T

High Voltage H.T.

Output 1200 V. 200 m.a.

Types 32 or 32A Input 12 volts 32 amps.

Types 33 or 33A. Input 24 volts 16 amps.

CLYDESDALE'S
PRICE ONLY

26/1

BRAND NEW—Ex. R.A.F.

A1134 BATTERY AMPLIFIER

Two Stages, Two Valves, VR21; PM2HL
VR35 QP22B, with Mic, QPP input and
output transformers, for inter-com, pre-
amp, or mod. Unit Complete in metal
case 7in. x 5in. x 4½in. finish black.
With Circuit.

CLYDESDALE'S PRICE ONLY **15/-** each. POST PAID

SEND NOW FOR NEW ILLUSTRATED LIST.

(Write Name and Address in BLOCK LETTERS please).

CLYDESDALE SUPPLY CO LTD

● The Radioman's Shop ● CES ELECTRONIC EQUIPMENT

R-RCVR. Units R. 1155 Receiver

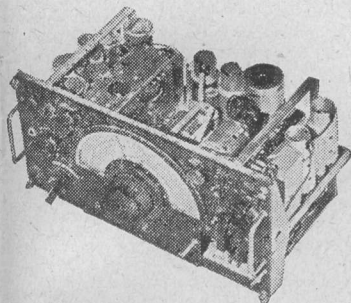

A 10 Valve Communication and D.F. Rcvr. for 18-3 mcs. 1500-600 kcs. 500-75 Kcs. in 5 W.B. complete with valves, Circuit and plugs etc., in metal case 16½ x 9 x 9ins. less power pack. "Airtested" before despatch.

CLYDESDALE'S PRICE

ONLY **£12/12/0** each.

CARRIAGE AND PACKING PAID
Full details on request.

T.1154 - R.1155

L.T./H.T.

Outputs—7.2 V. 13 amps.
225 V. 110 m.a.

Types 34 or 34A. Input 9.3 volts 23 amps.

Types 35 or 35A. Input 18 volts 12 amps.

at
3/11 each.

CARRIAGE
PAID

BRAND NEW—
JUNCTION PANEL 10D/13336
for the A1134

Contains matching sockets, terminal blocks etc., mtd on a board 6in. x 4in.
CLYDESDALE'S PRICE ONLY **4/6** each. POST PAID

BRAND NEW—
ELECTRO-MAGNETIC
MICROPHONE for A1134

Imp. 50 ohms, with switch, short lead and two-way socket.
CLYDESDALE'S PRICE ONLY **5/6** each. POST PAID

BRAND NEW—
CERAMIC WAFER
ROTARY W/C SWITCH
3 Ceramic (Wearite type).
Wafers. 5 positions
Single Pole each.
Overall length 8in. x 2½in.
wide. Ask for CWS351E.
CLYDESDALE'S PRICE

ONLY **3/11** each.
POST PAID

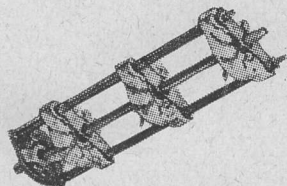

CERAMIC COIL FORMERS

Length 30mm. Overall dia. 20mm. dia. of centre 11mm.
As used in R.F. Units, 24, 25, 26. Ask for C.F.1.E.

CLYDESDALE'S PRICE ONLY **6d.** each. POST PAID

4/6d. dozen.

2 GANG TUNING CONDENSER

Max cap 500pf. per section, with trimmers, ceramic insulation.
Size 2½in. x 3in. x 2in. Ask for D46.

CLYDESDALE'S PRICE ONLY **7/6** each. POST PAID

VARIABLE AIR SPACED CONDENSER (Stratton 339)

Lab built, on DL9 insulation, brass vanes Caps. 3/50pf. or 2/100pf or 4/200pf. as connected. Size 2½in. x 2½in. x 1½in.
Ask for D49.

CLYDESDALE'S PRICE ONLY **4/11** POST PAID

CIRCUITS

Circuits available : T.1154, 2/3d., R.1155, 1/3d., B.C. 348, 1/3d., R.1116, 2/3d., M.C.R.1., 2/9d., R.1124, R.1125—P.U., 1/9d., R.1224, 1/3d., I.F.F. (U.S.A.), 1/9d., SCR-274-N (Command Eq.) 4/6d., SCR-269-A (Compass), 2/6d., A1134, 1/3d., R1147, 1/3d., R1132/R1481, 1/3d., all post paid.

CO-AXIAL CABLE

Coil (12 yds) first class co-axial cable. Approx. 80 ohms. 12 mm.
CLYDESDALE'S PRICE ONLY **7/6** Per Coil. POST PAID

Any length of Top Grade Co-axial Cable. 52 ohms. 12 mm.
CLYDESDALE'S PRICE ONLY **6d.** Per Yard. POST PAID

Minimum length 20 yards. 10/-

BRAND NEW, in maker's carton
A MAINS MOTOR
for 200-250 volts A.C. by simply wiring, data supplies.

MOTOR GENERATOR TYPE 29
Input 24 volts. 16 amps. Output 1200 volts. 200 ma. Dimensions 11 x 5½ x 5½ins.
Very useful for light bench work, a 1in. spindle is available for driving when the fan is removed.

CLYDESDALE'S PRICE ONLY **25/-** each. POST PAID



2 BRIDGE STREET, GLASGOW, C.5

'Phone : SOUTH 2706/9

VISIT OUR BRANCHES IN SCOTLAND, ENGLAND AND NORTHERN IRELAND

BOOK REVIEW

QRP CONTEST

“Very High Frequency Techniques”: Published by McGraw-Hill Publishing Co., Ltd., Aldwych House, London, W.C.2. In two volumes, Vol. 1 554 pp., Vol 2 476 pp. 84/-

These two most interesting volumes have been compiled by the staff of the Radio Research Laboratory at Harvard University, and deal mainly with techniques of general interest at frequencies above 100 Mcs. They are well printed on high quality paper, and are very comprehensively illustrated.

Volume 1 contains 22 chapters dealing with various types of aerials, impedance matching, ultra high-frequency measurements, direction finding, and honing systems, power generation, various types of oscillators, including resnatrons and magnetrons, and modulators.

Volume 2 deals more with the receiving side, and its 13 chapters cover power measuring devices, general receiver considerations, transmission line filters, tuners, detectors, and mixers, local oscillators, intermediate frequency amplifiers, receiver output circuits, and measuring equipment.

The present-day trend towards the higher frequencies demands comprehensive data and information on these techniques. Such information has, up to now, been very scarce, and particularly in the case of the magnetron—an essential in war-time radar equipment.

Data has been included on the operation and characteristics of typical magnetrons.

The above synopsis is necessarily very sketchy, as our space is so limited, so that it is impossible to more than indicate roughly the ground covered. Much of the information contained therein will doubtless be “above the heads” of our average readers, but it is equally certain that a great deal of it will be of interest and value to those, particularly the transmitting amateurs, who are interested in the new high frequency bands which are gradually being released.

H.O.

Our companion journal “Short Wave News” is sponsoring the Second SWN QRP Contest. For those readers of Radio Constructor who are actively interested in low power transmissions we are repeating the details and rules of the contest in the hope that they will join in the fray and help to make the affair an even greater success than the first contest was.

RULES AND CONDITIONS.

- (1) To be held over the period of Friday, October 29th (2200 GMT) to Sunday, October 31st (2200 GMT).
- (2) Power supply to the transmitter is limited to one standard 120 Volt HT battery.
- (3) Power output is limited only to that which can be obtained the battery.
- (4) A contestant may contact any given station more than once, providing that not more than one contact is made per band with that station.
- (5) Contestants may choose any, or all, of the following bands: 1.8, 3.5, 7 and 14 Mcs.
- (6) Either AC or DC can be used to supply the filaments of the valve(s).
- (7) No signal transmitted with a T7 note (or under) will be allowable.
- (8) Conditions of the licence must be observed.
- (9) Contest is restricted to stations with the following prefixes: - G, CC, GD, GM, GW, GI.
- (10) Points to be scored as follows: One point per contact multiplied by the number of countries worked, multiplied by the number of bands worked—provided that at least five stations are contacted on each band. Thus:—

25 stations worked	25 points.
3 bands used.	25 x 3 75 points
10 countries worked.	25x 3 x 10 750 points.

- (11) Completed logs, typed if possible, must be returned to this office within 14 days of the close of the Contest. Address logs to “QRP Contest,” c/o Short Wave News.
- (12) Details of equipment used during the contest must be submitted with final log (and a photo of gear if possible).

FROM THE MAILBAG

WALKIE TALKIES

Dear Sirs,

With reference to the article on modifying Walkie Talkies (August issue, page 342), I am afraid that I do not agree that improvement of the RF stage results in no great increase in efficiency.

In the 18 Set series, the RF stage was roughly tuned by the PA tuning circuit (see Fig. 1). I say "roughly" because normally the PA tuning circuit would be adjusted for maximum dip in anode current and would probably be far off the correct tuning for the receiver RF stage.

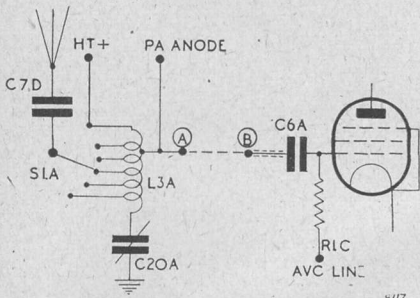

Fig. 1. (left) the TX PA circuit and (right) the RX RF stage. "A" goes to the RF socket on TX panel and "B" goes to RF pin on RX 5-pin plug. In the 18 Set, the circuits are permanently connected as shown by the dotted lines from A—B.

However, when it was desired to receive a station, and the TX was not required, a considerable increase in signal strength was obtained by tuning the TX PA circuit for maximum signal strength. So that, the No. 18 Set, when used for reception only, should be provided with a tuned circuit for the RF stage. A suitable circuit is shown in Fig. 2.

Sincerely yours,

G. H. HEPPEL, GM2DRB (Sutherland)

* * *

Dear Sirs,

Why not a Feature Circuit of the Month? This would consist of a theoretical diagram only and to be any type of gear (receivers, transmitters, amplifiers, etc.), either battery or mains, and which has been built using ex-WD gear.

Can anyone tell me of a quick and efficient method of curing binding vanes on the R1155 receiver tuning variables without removing them?

Sincerely yours,

A. W. MANN (Middlesbrough).

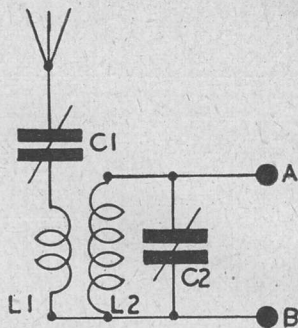

CO98

Fig. 2. L2 and L2 are standard SW coils to cover 6—9 Mcs. C1 is 100 μ F and C2 is 160 μ F. Points A and B are connected to RF pin on receiver and chassis respectively.

* * *

Dear Sirs,

Could any reader give me details of a small receiver, which appeared late in 1938 in a paper (NOT a radio magazine), in which I am particularly interested? The set in question used an old Lissen valve which had some peculiar internal connection, one single head-piece, and the whole thing worked from a 4.5 volt torch battery. At the time I built the set and it worked! Since then, the RX has been dismantled and the circuit lost, so that any help from readers would be greatly appreciated.

Best wishes,

K. J. BAILIE,

(10a, Neeld Parade, Wembley, Middx.)

THOSE VALVE BASES AGAIN

Dear Sirs,

With regard to the correspondence on paxolin bases on high frequency equipment, these frequencies are principally used for radar and require broad band-width. As most sets already have damping resistors across the tuned circuits, for this purpose, there is little object in using ceramic types except to withstand adverse tropical conditions.

Yours sincerely,

L. F. SINFIELD (Luton).

(Several correspondents have taken the wrong turning on this subject! In the original letter, E. J. Clarke asked why a ceramic valve-holder was used when the actual valve-base is normally paxolin or some similar material. The point was that if there was any leakage across the pins in the valve-base then there is no point in having ultra low-loss material in the valve-holder, since any leakage would already be present. Whilst we agree with L. F. Sinfield that for pulse operation a paxolin holder is satisfactory, we still have had no explanation to reader F. T. Randell's comment that on the RF 26 and 27 Units the coils are wound on moulded bakelite formers!—Ed.)

Inexpensive Television

By G2ATV & G3AYA

IN our last instalment we described a voltage-doubler type EHT supply, and stated that we used this type simply because the components needed were easily obtainable. We are now glad to report that the supply position regarding EHT transformers has improved greatly since then, and we have seen some very nice samples, including one which catered not only for EHT half-wave rectification, but included all LT and HT secondaries needed for the operation of the complete televisor.

C.R. Tubes.

Operating data on the VCR97 and 5CP1 cathode ray tubes is given in the following tables, and the base connections are shown in Fig. 1. The VCR97 tube, by the way, is best purchased with the 6A unit in which it is used, as the chassis with the tube mounting will be found most useful—see the illustration in last issue. The cost is little, if any, greater than is that of the tube alone, and the remaining components such as VR91's, VR54's, potentiometers, and so on, are not to be ignored, either. Similarly, the 5CP1 will be found in the Loran Indicator Units, type ID-6, AN/APN-4, which, besides the mounting arrangements, provides a veritable host of components for future use. Amongst these are numerous resistors, capacitors, potentiometers, valveholders, switches, some 30 valves of various types—some of these units are sold less valves—a 100 kcs. crystal, and LF transformers which are used in various oscillator circuits.

With both tubes, the holders should be arranged so that the key is either at the top or the bottom. Should the picture then not be the right way

up, or reversed as when looking in a mirror, it is simply a question of reversing the connections to the X and Y plates, or between pairs, in order to rectify matters.

VCR97 Network.

The circuit of the supply network to the various electrodes of the VCR97 is shown in Fig. 2. The heater is run from its own separate winding, either on the EHT, or one of the other transformers, and one side is joined to cathode to prevent any undesirable ripple modulation of the beam, and to prevent any excessive potential between heater and cathode.

R9 ensures a fixed amount of negative biasing voltage on the grid, the absence of which might damage the tube. VR8 is a variable bias control, and the spindle should be brought out to the control panel to allow the brilliance of the picture to be varied. The same applies to VR6, the focus control; careful adjustment of these two controls one against the other makes quite a difference to the clarity of the picture.

The resistors R3, 4, 5, and 7 are part of the potentiometer designed to give the correct relative potentials to the various electrodes. R3, 4 and 5 could consist of one resistor only, but as in the case of the EHT bleeder, the use of several resistors in series minimises risk of "flash-over."

Anodes 1 and 3 and the graphite coating are connected together (Pins 5, 7 and 10), and are taken to the junction of R1 and R2. One each of the X and Y plates, pins 8 and 9, are taken via decoupling resistors R10 and R11 to the same point. The other two deflector plates, pins 11

5 C P 1

U.S.A. Army — Navy preferred type, incorporating an intensifier for maximum deflection sensitivity.

Heater V	6.3 V
Heater I	0.6 A
Va1	— 575
Va2	— 2000
Va3	— 4000
Vg	— -60 cut-off.

Deflection sensitivity—

D1 D2	in mm/volt D.C.
	0.28
D3 D4	in mm/volt D.C.
	0.32

V C R 97 G. E. C. E-4504-B-16
MULLARD ECR-60

G.E.C.

Heater V	— 4 V
Heater I	— 1.1 A
Va1	— 2500 max
Va2	— Va3 x 0.175 mean
Va3	— 5000 max 1000 min
Vg	— -(Va1 x 0.04v) max.

MULLARD

Heater V	— 4V.
Heater I	— 1.0A
Va1-Va3	— 2500V
Va2	— 250 to 450V
Vg	— -1 to -100V

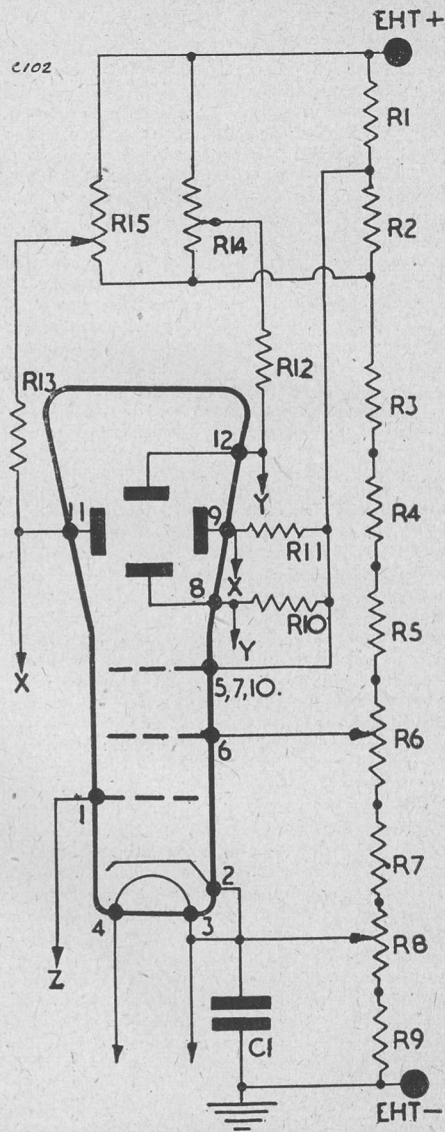
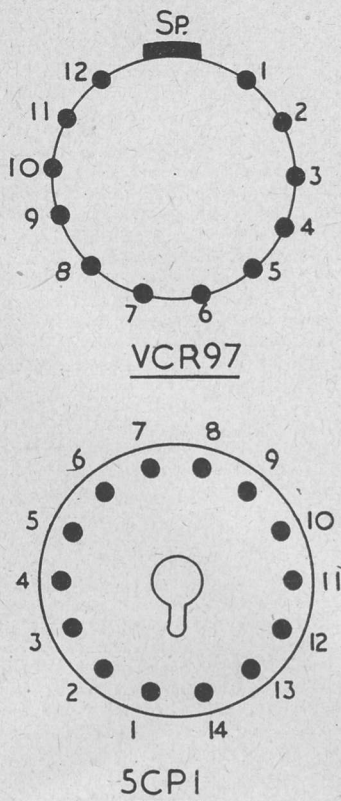

Fig. 1. Connections to tube bases as seen when looking at back of base. The numbering of the contacts for the VCR97 conforms with the numbering given in the tube network diagram.

Fig. 2. The connections for the 5CPI are as follows:—Pin 1—Heater; Pin 2—Cathode; Pin 3—Grid; Pin 4—blank; Pin 5—Anode 2; Pin 6—blank; Pin 7—Y1; Pin 8—Y2; Pin 9—Anode 1; Pin 10—X1; Pin 11—X2; Pins 12 & 13—blank; Pin 14—Heater. Side Connection—Anode 3.

and 12, are taken via their decoupling resistors to the sliders of VR14 and VR15, two potentiometers which are each connected across the two resistors R1 and R2. This allows the potential of these two plates to be varied above or below that of the final anode, thus providing a means of centring the spot, and the picture, both vertically or horizontally at will. Once adjusted, these two controls can be locked, and need not be brought out to the control panel, though they should be so positioned as to allow for free access at any time when it may be desired to adjust them.

Fig. 2. Circuit of the network used with the VCR97 tube. The tube connections in this diagram are numbered to conform with those given in Fig. 1. Component values are as follows:—

- R1, 2, 7. 250 kΩ
- R3, 4. 1 MΩ
- R5. 500 kΩ
- R9. 82 kΩ (not critical)
- R10, 11, 12, 13. 2 MΩ
- VR6, 8. 500 kΩ potentiometer
- VR14, 15. 1 MΩ potentiometer
- C1. 0.1 μF 500v wdg.

Construction.

There are one or two constructional points which should be borne in mind. In view of the high voltage involved, the various fixed resistors, and the capacitor, should be rigidly mounted. The capacitor C1 was found to be best fitted into the wiring, being connected from pin 2 on the tube base to the metal bracket holding the base. The resistors are best wired on a compound mounting strip, which can be conveniently situated underneath the 6A chassis. The potentiometer should be mounted either as in the original unit on metal brackets, with heavy insulating bushes, or else on paxolin brackets. Where the spindles have to be extended, as in the case of focus and brilliance controls, either insulated extension rods or insulated flexible couplers should be used. It is definitely not wise to rely on the potentiometer spindle being itself adequately insulated from the moving arm.

Wiring in and between the network and the EHT supply should be tackled as thoroughly as in that of the EHT supply, details of which were given last month. The heater wiring should be carried out in twisted cable. Long connections between the tube base and other points are liable to cause serious trouble through hum pick-up, particularly the leads from the grid, cathode, and deflector plates, and these connections should be made in screened cable (co-ax is ideal), the outer screening being earthed to the chassis. The resistors R10-11-12 and 13 should be located right at the tube base itself, in order to minimise any ripple getting through to the deflector plates.

Testing.

At this stage the tube and its supplies can be tested. The potentiometers should each be set roughly to a mid-way position, and on switching on a spot should appear on the screen. It may be necessary to turn up the brilliance control, but should the spot be too brilliant, this control should immediately be adjusted until the spot can just be seen. It is easy to burn the screen, especially when the spot is stationary, so it is best to play safe by having the spot just visible. Next step is to vary the focus control, VR6, until the spot is as sharply defined as possible. It will probably be necessary to regulate both VR6 and VR8 together, as focussing the spot decreases the size, and at the same time makes it more brilliant. Next follows the centring of the spot, the position of which is controlled by VR14 and VR15. It should be possible by manipulating these two controls to move the spot from above to below centre, and from left to right of centre.

A circular, sharply defined small spot should be obtained when the controls are properly adjusted. Should nothing at all appear on the screen, of course, it would indicate a fault either in the EHT supply or the network, in which

case voltages should be checked on the various electrodes. A voltmeter of suitable range can be made use of to indicate the presence or otherwise of a potential, though the reader should not take the scale reading as giving an accurate indication of the figure of voltage present.

When the spot is obtained, it may not focus sharply, or may even not be circular. Turning the focus control from maximum to minimum should cause the trace to gradually sharpen from a blurred image to a point of maximum sharpness, and then to gradually blur again. Should this not be so, it would indicate that the wrong DC potential exists at this part of the network, and the values of components should be checked. If the sharpest image or spot obtainable is still blurred—do not forget to keep the brilliance low—then the trouble may be due to an interfering magnetic field. Try rotating the EHT transformer, and if this gives no great improvement try the effect of placing a steel or iron (tinplate) screen between the tube and the transformer.

EHT Power Supply.

We have been asked to give a suitable circuit for a half-wave rectifier instead of the voltage-doubler circuit given last month, in view of the fact that suitable transformers are now available. Fig. 3 shows a typical arrangement using a single rectifier such as the HVR2, and which is directly interchangeable with the voltage-doubler from the points marked HT+ and HT-.

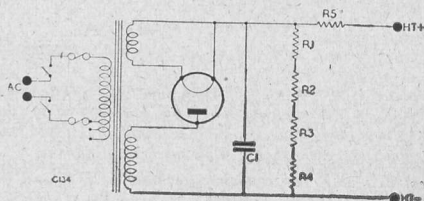

Fig. 3.

C1 is not at all critical, and a good average value is 0.1 μ F, rated at 3,000v wkg. or higher. This latter figure assumes that the EHT is from 2,000—2,500 volts. R1, 2, 3 & 4 represent a bleeder network to discharge C1 after the television has been switched off, the four resistors being used so that the voltage across any one is less than 1,000, so obviating risk of flash-over. A value of 500k ohms for each one is suitable. R5 is inserted to limit the current flowing, and thus to safeguard the rectifier and transformer, in the event of a low resistance or short circuit developing further on in the tube network.

To be continued.

Rapid Matching Calculations

By K. KEMSEY-BOURNE

This article describes methods for quickly calculating transformer ratios for matching output stages to speakers, recording heads, lines, etc. It includes a special Matching Chart, with details of how to make a Wall Chart for the shack or club-room.

Introduction.

Probably the most frequent calculations done by the radio constructor are simple voltage-current-resistance relationships worked out by Ohm's Law, $E = IR$.

Almost as regular are ratio calculations for transformers used to match different impedances—microphone to grid, valve anode to grid, or output stage to loud speaker. This article deals with output stage calculations in particular, and shows how they may be simplified and quickened; the methods used may be extended to similar problems.

Standard Formula.

This well-known formula connecting transformer turns ratio $n : 1$ with primary and secondary load resistances or impedances P and S

is $n = \sqrt{\frac{P}{S}}$ which is derived from the current-voltage relationship in the two windings. Whether this is a step-up or step-down ratio is fairly obvious from the value of n . For example, if the output stage of a set or amplifier has a load of 6,000 ohms and is to be matched to a 15 ohm

speech coil, then, substituting for P and S , we

have $n = \sqrt{\frac{6,000}{15}} = \sqrt{400} = 20$, and the transformer ratio is 20 : 1, that is, step-down.

For step-up ratios it is simplest to write $N = \sqrt{\frac{S}{P}}$ for a 1 : N transformer ratio.

Calculations.

In practice these calculations can be clumsy to perform, especially if it is necessary to do a series of them. Many of us find difficulty with square roots of large numbers, and the use of logarithms is over-accurate and slow.

Two methods will be described here; the first uses an ordinary slide-rule, and the second a special chart. Full instructions will be given for making one's own large chart for the wall of the shack or workshop.

The Slide-Rule.

This method is useful for special cases not covered by the chart. On the ordinary slide-rule the A scale gives squares of numbers immediately below on the D scale, and thus we may

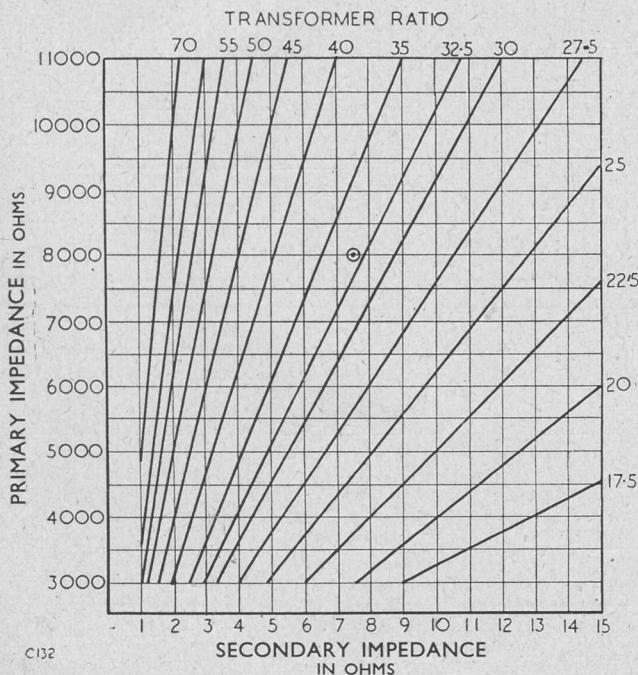

Fig. 1. Matching Chart for rapid indication of correct transformer ratios for output stage matching. See examples in text.

take square roots without moving the slide. If we find the fraction $\frac{P}{S}$ in the normal way on the A scale, then $\sqrt{\frac{P}{S}}$ will be down on the D scale directly below the index.

The calculation summarises thus: Set on A scale $\frac{P}{100}$, divide by S on the B scale, read off D scale below index, and multiply by 10 (because we divided by 100, and $\sqrt{100}$ is 10). Perhaps a couple of examples will assist.

Example 1.—What transformer ratio is needed to match a 6F6 output stage, 10,000 ohms optimum load, to a 15 ohm recorder?

Dividing 10,000 by 100 we get 100, which we set on the A scale, at the extreme right. We move the B scale so that 15 comes directly under 100 on the A scale. At the left-hand index of the B scale we find on the A scale 6.68, which is, of course $\frac{100}{15}$, and immediately underneath we find on the D scale 2.58. Thus the step-down ratio required is found to be $2.58 \times 10 = 25.8$ to 1.

Example 2.—What ratio will match a 6L6, 6,000 ohms load, to a 2.5 ohms speaker?

Dividing 6,000 by 100 we have 60, which we set on A, and under it on B we put 2.5. Reading off on D opposite the index we find 4.9. Required ratio is $4.9 \times 10 = 49$ to 1.

Accuracy Needed.

Output matching is not closely critical, and it is clearly a waste of time to calculate transformer ratios to several figures and have transformers built to correspond when all the time the impedance of the speech coil we are matching varies with frequency over a wide range. Speech coil impedances are usually specified at 400 cycles, where they are at or near their lowest value. A nominal 2.5 ohm speaker commonly has an impedance of 15 to 20 ohms at 60 cycles, 5 ohms at 100 cycles, 2.5 ohms at 400 cycles, 5 ohms at 1,000 cycles, 10 ohms at 3,000 cycles and 20 ohms at 10,000 cycles.

This is not to say that output matching should be done carelessly or ignored; the point is that when the ratio has been calculated then transformers of the indicated ratio plus-or-minus 10% are normally permissible. Now look at the Matching Chart, Figure 1.

Matching Chart.

The Chart indicates immediately the step-down ratios for matching any output stage of 3,000 to 11,000 ohms optimum load to speakers,

(continued on page 404)

Ratio		17.5	20	22.5	25	27.5	30	32.5	35
Join	X	9	7.5	6	5	4	3.3	3	2.5
	Y	3,000			3,100	3,000			
To	X	15	15	15	15	14	12	10.7	9
	Y	4,550	6,000	7,600	9,400	10,700	11,000		

Ratio		40	45	50	55	60	70
Join	X	1.9	1.5	1.2	1	1	1
	Y	3,000			3,050	3,600	4,900
To	X	7	5.5	4.4	3.6	3	2.2
	Y	11,000					

Fig. 2. Table giving the points to be joined by straight lines to construct the 14-ratio Matching Chart shown in Fig. 1.

Radio Simplified

By A. J. Duley

Part 6 (conclusion)

Bridge Theory.

IT is proposed in this article to go back to mechanical analogy, our pipe of water. In

Fig. 1 we see that the water flows down the pipe, is split into two parts, and converges again to flow into one pipe. A pipe is also shown joining the two diversions, and in this pipe a means of measuring flow is inserted.

The water will flow down both diversion pipes, and no flow will take place through the joining pipe until an obstruction of some kind gets into the way of one of the following streams.

Suppose that we have one inch piping, and the water flows along without obstruction, and by using couplings, we can take out a one inch pipe and put a half-inch pipe in one side. This alters the flow of water in the one side, and water flows in the middle tube and causes the flow meter to operate.

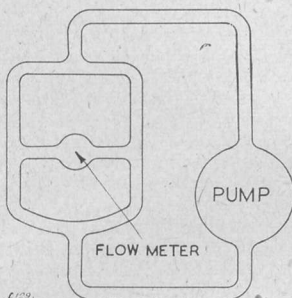

Fig. 1a

This can be done electrically too. If the pump is replaced by an electric battery the two arms are replaced by upper wires, and connected to the battery, as in Fig. 1(b) with a current meter needle to deflect, owing to current flowing in the centre limb of the network. Taking this idea further, we can substitute resistance for the wires as shown in Fig. 1(c) and for a null reading on the meter

$$\frac{R1}{R2} = \frac{R3}{R4}$$

If we make R1 and R2 a fixed quantity, say 1, 2 or any fixed number, R3 is equal to this quantity times R4 because

$$R1 \times R4 = R3 \times R2.$$

$$\therefore \frac{R1}{R2} \times R4 = R3$$

$$\frac{R1}{R2}$$

By making $\frac{R1}{R2} = 1$, and making R4 variable, we can use the bridge for measuring resistance values direct. This would limit the scope of the instrument, however, and a fixed ratio of 1 to 1,

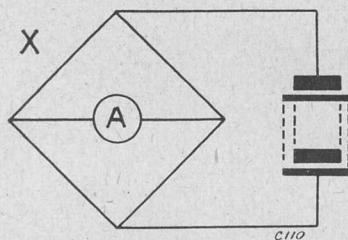

Fig. 1b

100 to 1, or 1,000 to 1 is used, and R4 is calibrated accurately. R3 is connected to the bridge by means of test terminals, and the bridge is balanced, that is the setting is adjusted until no reading is obtained on the meter.

In a case at hand, the ratio arms were at 100 to 1, that is R1 was 10,000 ohms and R2 was 1,000 ohms. R4 was a wire-wound potentiometer of 2,000 ohms resistance maximum, and the setting read 1.500 ohms. The resistance was found from

$$R3 = \frac{R1}{R2} \times R4 = \frac{10,000 \times 1,500}{1,000}$$

$$\therefore R3 = 150,000 \text{ ohms.}$$

Capacity Bridges.

Having absorbed the basic idea of bridges, figure No. 2 should be easy to understand, and it will be seen that

$$\frac{R1}{R2} = \frac{C2}{C1}$$

The factor we measure in this case is the impedance of the capacitor against the resistance of the resistor, and the impedance of a capacitor varies inversely as the capacity, that is as $\frac{1}{\text{capacity}}$.

Similarly to the resistance bridge, the ratios of R1 to R2 can be varied by means of using a potentiometer, and using various capacitors to extend the range. An A.C. supply is needed in this bridge, and an L.F. oscillator as described

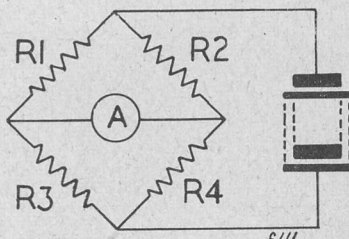

Fig. 1c

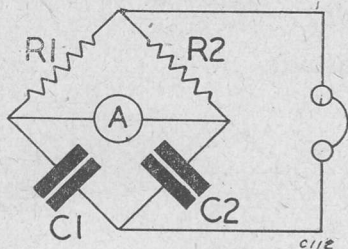

Fig. 2

previously is admirable. Detection of null point is achieved by using headphones. Due to stray capacitance effects in the oscillator, the sound never actually disappears, but the minimum point is easily distinguished.

In a case recently, the test capacitor gave a minimum signal with a 0.001 μ F capacitor in the circuit, and the potentiometer, a 2,000 ohms wire-wound, showed a reading of 1,600 ohms. In this case, it meant that the ratio of resistances in the circuit was $\frac{1,600}{400}$ and the capacity was found

as follows:—

$$C2 = \frac{1600 \times 0.001 \mu F}{400}$$

$$\therefore C2 = 0.004 \mu F.$$

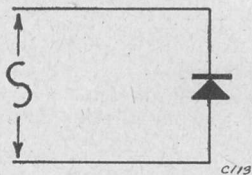

Fig. 3a

Bridge Rectification.

If a rectifier is connected in a circuit as shown in Fig. 3(a), a half wave form of rectification is obtained, and whilst for many purposes this is sufficient, it is often desirable to include full-wave rectification. To this end the bridge circuit

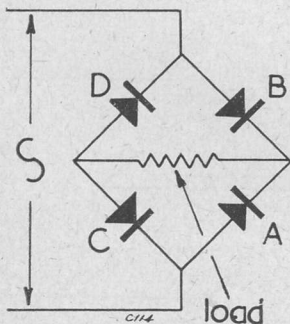

Fig. 3b

shown in Fig. 3(b) is used. If the current is flowing from bottom to top of the diagram, the flow first takes a path through arm A, as C has high resistance in that direction. Similarly, the path through arm B is barred, and the current must go through the load and via arm D to the external circuit. If the flow is in a contrary direction, arms B and C via the load are used, so that a one way current system is maintained.

The Cathode Ray Tube.

The action of a thermionic valve has been dealt with in a previous article, and whilst this is a fact of common knowledge, the writer intends to reiterate the essential principles.

A cathode is heated, electrons are given off from the heated surface, and these electrons have a negative charge. When a positive

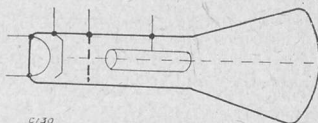

Fig. 4. A simple cathode ray tube.

potential is applied to the anode, the electrons are attracted to it in a stream. A grid, or mesh of wire interposed between the anode and the cathode, controls the flow according to the potential applied to it. That recapitulation was given to freshen the facts in the minds of readers, so now let us look into this cathode-ray tube business.

In the cathode-ray tube, a similar system is used to that in the valve, the only difference being that the anode is a tube instead of a metal plate, and the electron stream passes through this anode on its way to the fluorescent screen at the end of the tube. Fig. 4 shows the set-up for this, and by this means a bright spot is formed on the end of the tube. To concentrate and control the beam, a variety of methods are used.

Magnetic Deflection.

In this type of deflection, use is made of the fact that magnetic fields affect the electron beam, and by placing two pairs of coils so that the magnetic field of one pair is at right angles to that of the other pair, the beam can be deflected in both horizontal and vertical directions.

Fig. 5 shows this method of deflection.

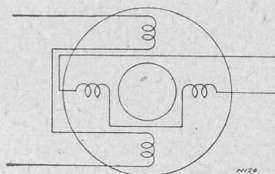

Fig. 5. Magnetic Deflection.

Electrostatic Deflection.

This method of deflection on a cathode-ray tube is dependent on the fact that the electron beam is attracted by a potential of positive sign, and by supplying this potential to a pair of plates, through which the beam passes, the beam can be deflected. Two pairs of plates are used, forming in effect a hollow box, in order to give both vertical and horizontal deflection. This method is shown in Fig. 6.

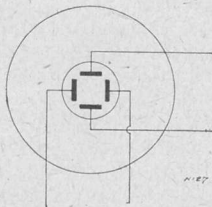

Fig. 6. Electrostatic Deflection.

The Time Base.

From the above data, it will be understood that graphs can be drawn with the tube, and for radio work this is very useful. Those of you who are used to graphs will know that horizontal lines are the "X" direction and vertical the "Y" direction, and in the C.R. tube the deflector plates mounted vertically pull the beam horizontally, and are known as "X" plates; the horizontal plates, which cause the beam to rise and fall, are called "Y" plates. If we connected the output of an alternator to the "Y" plates, the beam would rise to a maximum, fall to a point representing zero voltage, and then to a minimum, but the spot would be all in one line. What is needed is a device to extend the line, and the apparatus to do this is called a time base. Circuits used for this purpose are essentially oscillators with an output which has a "saw tooth" waveform, as in Fig. 7., in which the scanning time is long compared with the time for the "flyback," as it is called.

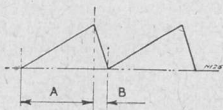

Fig. 7. A "saw tooth" waveform. A is the Scanning Time and B is the "flyback."

The time of scan can be adjusted so that, say, one sine wave would fill the screen when an alternating voltage is connected across the "Y" plates.

The cathode-ray tube can be used to measure other types of quantities as long as the potentials

are applied to the "Y" plates. For example, for drawing the graph of a P-V curve in a motor car engine, the pressure acts on a type of microphone, and the resultant electrical potentials are amplified and then applied to the "Y" plates.

It is hoped that this series has made some principles of radio a little clearer to the reader. In view of the range of work covered, the depth to which we have gone has not been great—for that I apologise.

ARE YOU A VIEWER ?

If you are the owner of a television receiver, or are building one—either from our articles or from any other designs—then here is a news item of vital interest to you.

Towards the end of this month, dated November, will appear the first issue of our third magazine. This project will be called

"Television News"

The magazine will be devoted to news, views and reviews (pardon the unintentional poetry !) connected with television. Advance details of the month's programmes, interviews with artists and television personalities, manufacturers' reviews, criticisms of previous programmes, television news from our overseas correspondents, news items of television happenings and developments from our reporters, and other items of interest to the viewer, will be regular features.

"Television News" will be published monthly and will retail at 1/-. Your copy may be obtained from your local bookseller or, in cases of difficulty, direct from the publishers. We are able to accept annual subscriptions and on receipt of 13/- will mail you your copy each month for one year.

Our latest venture is, we feel, well timed since the interest in visual radio is fast accelerating. When you are an ardent viewer, (and who is not when once having sampled television)? it is natural that you will want to know about your favourite stars, what future programmes are in store for you, what the latest developments are, and if others feel the same way about certain programmes that you do. Television News will fulfill these wishes.

We would be pleased to send a sample copy to any interested readers on receipt of a P.O. value 1/2.

IF YOU HAVE ANY FRIENDS WHO ARE KEEN VIEWERS IT WOULD BE GREATLY APPRECIATED IF YOU WOULD PASS ALONG THE DETAILS OF "TELEVISION NEWS." THANK YOU !

RAPID MATCHING CALCULATIONS—

(continued from page 400)

etc., having impedances of 1 ohm to 15 ohms, a range that covers most requirements for battery and mains valves, single or push-pull.

The method of use is simple. On the Y-scale is the output stage load, and on the X-scale is the speaker's load. Each sloping line corresponds to one step-down ratio, as marked. Plotting a point in the normal way from X and Y values, note the line that passes nearest to that point and read off the ratio marked. Equally, the Chart shows what impedances may be matched by a transformer with a given ratio. An example will illustrate.

Example 3.—Push-pull PX4's, 8,000 ohms load anode to anode, are to be matched to two 15 ohm speakers in parallel, i.e., effective secondary load is 7.5 ohms.

Plot 7.5 on the X-scale against 8,000 on the Y-scale, as shown on Figure 1. The line passing nearest this point is marked 32.5, indicating a step-down ratio of 32.5 to 1. As mentioned above, ratios of 35:1 and 30:1 will serve.

The Chart will give ratios for secondaries of 100 to 1,500 ohms, which is useful for some purposes. Use the X-scale as if it were multiplied by 100 and divide the ratio found by a factor of 10. Thus:

Example 4.—To find ratio for matching a 10,000 ohms output stage to a 600 ohm line, use the Chart as though matching 10,000 ohms to 6. This gives a ratio of 40:1, and thus the required ratio is 4:1.

Constructing the Chart.

Having fixed on a sheet of graph paper scales convenient for your purpose, construct the sloping lines by joining with a ruler the two (X Y) points given for each ratio in the table, Figure 2. Reference to Figure 1 will help.

Vertical and horizontal lines drawn in red corresponding to the impedances you commonly use will be found a help in computing the most useful ratios for experimental purposes.

(G3XT—continued from page 393)

As regards valves, almost any good detector or LF type will work in the first two stages, and for the output stage one has a choice of power triodes, tetrodes or pentodes. With the two latter, signals should be strong enough to work a sensitive moving-coil loudspeaker, but personally I prefer headphones as the set is in the living-room and the rest of the family may not want to hear morse signals for hours on end!

**SECOND AMATEUR
RADIO EXHIBITION**

The Second Annual Amateur Radio Exhibition, organised by the Inc. Radio Society of Great Britain, will be opened at 2.30 p.m. on Wednesday, November 17th, 1948, by Dr. R. L. Smith-Rose, Director of Radio Research, Department of Scientific and Industrial Research, and an Honorary Member of the Society. The exhibition will remain open until November 20th (hours, 11 a.m. to 9 p.m.).

The venue is the Royal Hotel, Woburn Place, London, W.C.1 (nearest Underground station, Russell Square. Bus routes 68 and 77 pass the door).

Twenty-seven radio concerns have reserved space—a considerable increase over last year. The G.P.O. are to stage a special exhibit.

Admission will be by catalogue, price 1/-, purchased at the door, or 1/3 on application to the Society (New Ruskin House, Little Russell Street, London, W.C.1.

IN OUR NEXT ISSUE

Another article on surplus gear is scheduled for next month. This time it is the well-known receiver the R109. For the transmitting enthusiast we have a 60-watt modulator as used by G2BQC. L. F. Sinfield returns to these pages with a new idea, or rather a new angle, on Franklin oscillators. For the receiving section, F. K. Parker has a few extra words and modifications concerning his TRF5. Part 3 of the Inexpensive Television series will be appearing as also will be the "regulars." The AC/DC fraternity will be interested in Len Miller's article on Biasing Problems. Plus, of course, supporting features!

FUTURE READING

We have many fine articles on file and just to give you an idea of the selection here are a few samples:—

A Table Top Transmitter, Housing that Receiver, Improving Selectivity, Trouble Shooting in Superhets, AC/DC Amplifier, A Useful Inter-Communicator, Three Station Preselector, Pre-selection, A C/R Bridge, Inexpensive Multi-Range Meter, Signal Generator for the Amateur.

We have, of course, many articles on the conversion and adaptation of "surplus" gear and we hope to use one in each issue.

Our only complaint (and yours, too!) is that in these austerity days we are greatly restricted with regard to space. However, one day. . . .

TRADE REVIEW

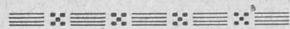

The TAYLOR TYPE 30a OSCILLOGRAPH

TEST REPORT

This general purpose oscillograph incorporates a 3½" electrostatic tube (a Mullard E.C.R.35) having a green trace. Both a variable frequency time-base generator and a push-pull vertical gain amplifier are provided.

Dealing first with the amplifier, this has two controls: a decade type switch marked x1, x10 and x100 and a continuously variable control which covers gain from zero to the maximum of the switchsetting. Maximum overall gain is 120 times.

Horizontal deflection is obtained from either (1) the variable frequency time base, (2) mains frequency from a special tapping on the transformer, (3) or from an external source. Two controls are provided here, a selector switch to give "Direct," "50 cycles" and "internal" and a continuously variable potentiometer for the deflection voltages. Time base frequency similarly has coarse and fine controls. The coarse one gives six ranges as follows 10—30, 30—100, 100—300, 300—1,000, 1,000—3,000 and 3,000—10,000 sweeps per second. From appropriate terminals this time base, which is Thyatron operated, is available for external use.

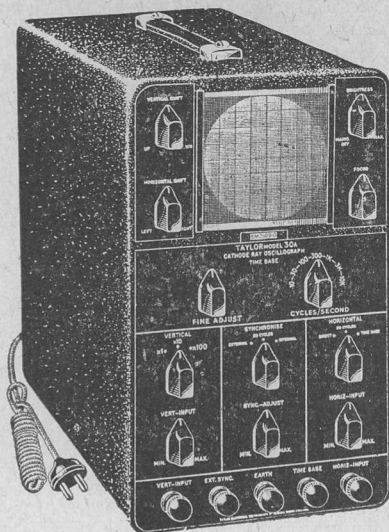

Direct connection to the tube deflector plates is provided and brought out to a small plug and socket panel at the rear of the instrument.

For comparative and actual measurement purposes, a detachable graticule is provided. This is marked in cm. and mm. squares.

Although a total of 12 controls are fitted, these, together with the terminals, are arranged for maximum convenience on the front panel of the instrument.

The panel, chassis and case are of steel and the instrument is finished in an attractive shade of blue crackle enamel.

Power supply is either 100—120 or 200—250 volts A.C. at 40—100 c.p.s.

On test in a variety of jobs the instrument was found to be very flexible and convenient in use. Capable of sharp focussing the spot was sufficiently bright in a normal workshop without the brilliance control being "all out."

The smooth and positive action of all controls was noticeable, the "shifts" having adequate range.

Summing up, this is a useful oscillograph capable of many applications in the workshop and can be recommended for the constructor and experimenter alike. The price is £29/10/0.

SMALL ADVERTISEMENTS

Readers' small advertisements will be accepted at 3d. per word, minimum charge 3/-. Trade advertisements will be accepted at 6d. per word, minimum charge 6/-. If a Box Number is required, an additional charge of 1/6 will be made. Terms: Cash with order. All copy must be in hand by the 10th of the month for insertion in the following month's issue.

PRIVATE

SPECIAL OFFERS. Signal Generator, Type I-72, 100 kcs to 32 Mcs—£10. Microphones, Type T17—10/- each. Keys, Type J47—5/- each. One set of three matched tuning units, TU5B, 6B, 7B—£2 the set or 15/- each unit. Sets of aerial equipment, comprising 150 ft. covered wire, two guys with pulleys, etc., insulators, 15ft. "lead in" (2kV wkg)—14/- the set. Equipment chests (a) 44 inch x 15 inch x 11 inch (steel bonded)—30/- each. (b) 26½ inch x 12½ inch x 11 inch—10/- each. Would make ideal tool chests. Transmitting insulators—6d. each. Also the following British equipment: One receiver Type 81B (3 valve superhet) with modulator Type 77B modified as amplifier (seven valves), can be used separately or added to receiver—£5 the lot, inclusive circuits. All enquiries to:—J. C. Ward, "Lyttleton," Colwall Green, Malvern, Worcester.

Sale. 1224A receiver in brand new condition, in 100% working order—£4/5/0. E. W. Jordi, 103, Gloucester Road, South Kensington, London, S.W.7.

TRADE

SMITH FOR RADIO. All types of components supplied. "Q" Coils, Valves, Transformers, etc. Quick Service. Send for requirements C.W.O. or C.O.D. Send stamp for list.—98, West End Road, Morecambe.

QSL's and G.P.O. Approved Log Books. Samples free.—Atkinson Bros., Printers, Elland.

MAINS TRANSFORMERS, best makes from 23/6. EHT 2kv from 19/6, OP trans 30 watt, 10 ratio 23/6. Line trans 27/6, Focussing Coils 33/6, Scanning Coil. 29/6 and many others, all fully guaranteed. Range of American valves from 3/6 and others. S.A.E. for lists Duke & Co., 219, Ilford Lane, Ilford, Essex.

VALVES—10,000 in stock. Most types available. Send for valve list, enclosing S.A.E.: Ransom, Bond Street, Brighton.

COPPER WIRE. Enamelled, Tinned, Cotton, Silk-covered. All gauges. Screws, nuts, washers, soldering tags, eyelets. Ebonite and laminated Bakelite panels. Coil formers. Covered wires, earphones, etc. List S.A.E. Post Radio Supplies, 33, Bourne Gardens, London, E.4

G6MN for the "best" QSL's and approved log books, send for samples: G6MN, Bridge Street, Worksop, Notts.

*If you are a 'RADIO (or TELEVISION)
CONSTRUCTOR'*

It will pay you to call on us, or send S.A.E. for list of Ex-Govt. Units, new and surplus components, valves, C.R. Tubes, books, etc., etc.

**GARLAND RADIO (Dept. R.C.),
4 Deptford Bridge, London, S.E.8.**

Phone: TIDeway 3965



We have the finest stock of
British and American radio
books in this country.

Write or call for complete list—

**THE MODERN BOOK COMPANY
(Dept.RC)**

19-23 Praed Street, London, W.2

BARNES RAD-ELEC CO.

12 Pipers Row, Wolverhampton

(Central by stations and Victoria Sq.)

Are you on our Mailing List for BARGAINS? Deal with the firm connected with Radio since 1923: Among our 1,000's of items we offer new test panels in neat steel cases with 2—5m/a meters scaled m/a and Volts, switches, resistances etc., for £1; S.M. drives with ¼ coupling, fast and slow, smart panel job, 5/3; the Famous R.1116; all-wave; standard battery; 8V. Receiver for speaker at £11, TESTED—Send 3d. for Leaflets:

No Shop keeps all you want—we keep more than most. That's why people say—

"You'll probably get it at
SMITH'S
of Edgware Road"

Pay us a visit and see for yourself

H. L. SMITH & CO. LTD.

287-9 EDGWARE ROAD, LONDON, W.2

Near Edgware Road Met. and Bakerloo
Phone PÁD. 5891 :: Hours 9-6 (Thurs. 1 o/c.)